

REV.	CHANGE	DATE	BY

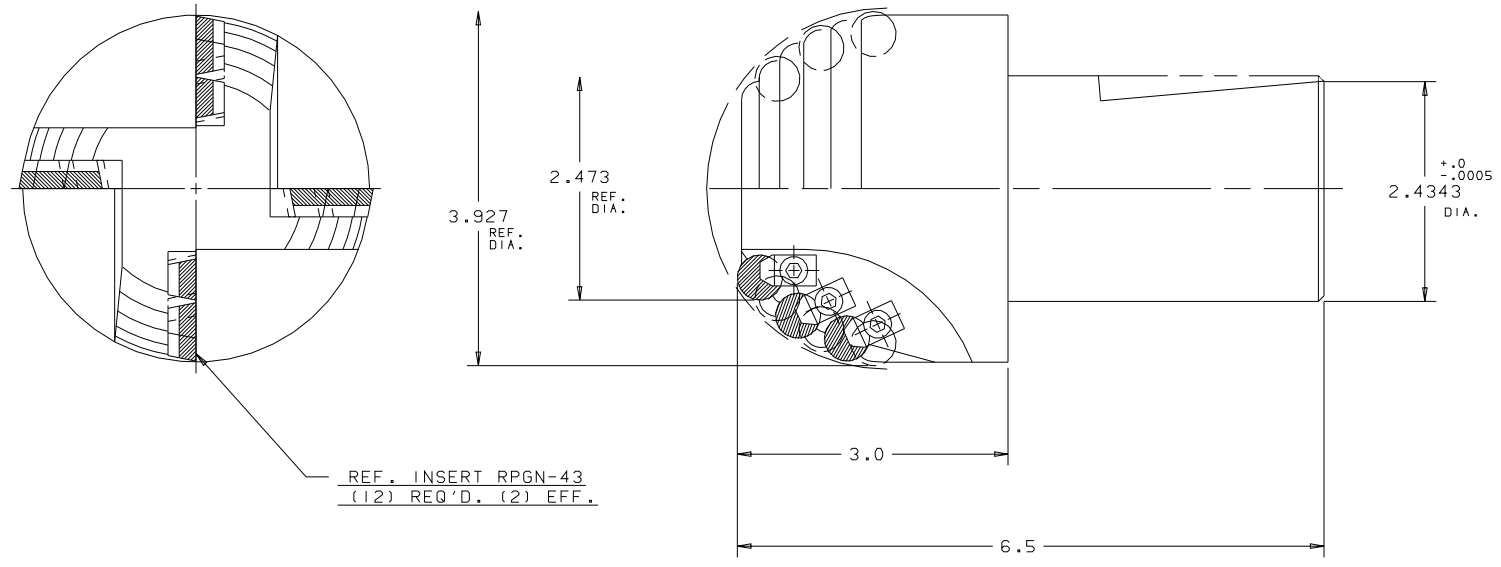

REF. INSERT RPN-43  
(12) REQ'D. (2) EFF.

ROUGHER  
BALL ENDMILL  
MATL. 4150 HT.TR. 35-39 R/C

DET. NO.	NO. REQ'D.	DESCRIPTION	FINISH SIZE	DWG. NO.
5	12	CLAMP SCR.	10-32 X 1/2	31 SHCS 10/32
4	12	CLAMP	3025-1	09 3025
3	12	ANVIL SCR.		31 FHCS 4/40
2	12	ANVIL		04 308341
1	1	BODY	163	521296-1

STAMP GREENLEAF	UNLESS OTHERWISE SPECIFIED:			DR.	CH.	SCALE:	GREENLEAF CORPORATION SAEBERTOWN, PA. 16433
	1. BREAK ALL SHARP EDGES			D.A.P.		FULL	
	2. STAMP TOOL NUMBER			9/ 9/97			
TOLERANCES:					DWG. NO.	CUSTOMER'S NAME	
3. ANGLES ±1/2°					163	521296	Q- #42890
4. 1 PLACE DECIMALS ±.030							
5. 2 PLACE DECIMALS ±.015							
6. 3 PLACE DECIMALS ±.005							